

MORNSUN

QC962 Hybrid Integrated IGBT Driver

QC962 is a hybrid integrated IGBT driver designed for driving N-channel IGBT modules in any gate amplifier application. The device provides the required electrical isolation between input and output with the opto-coupler. Short circuit protection is provided by a built-in desaturation detector. A fault signal is provided if the short circuit protection is activate.

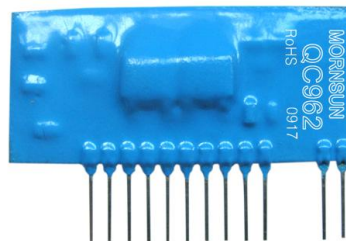

FEATURES

- Built in high CMRR opto-coupler (CMR:Typical: 30kV/μs, Min.:15kV/μs)
- Two supply drive topology
- TTL compatible input interface
- Electrical isolation voltage between input and output with opto-couplers (Viso=3750VRMS/min)
- Built in short circuit protection circuit with a pin for fault output
- Soft IGBT turn-off and protection circuit time reset
- Controlled time detected short circuit
- Switching frequency up to 20kHz
- Pin and characteristic are compatible with M57962AL

APPLICATION

- General-purpose Inverter
- AC Servo Systems
- Uninterruptable Power Supplies(UPS)
- Welding Machines

RECOMMENDED MODULES

- 600V Series IGBT(up to 600A)
- 1200V Series IGBT(up to 400A)
- 1700V Series IGBT(up to 200A)

MORNSUN Science & Technology co.,Ltd.

Address: 2th floor 6th building, Huangzhou Industrial District, Guangzhou, China
Tel: 86-20-38601850
Fax:86-20-38601272
[Http://www.mornsun-power.com](http://www.mornsun-power.com)

ABSOLUTE MAXIMUM RATINGS

Item	Test Conditions	Limit	Units	
Supply Voltage*	V _{CC}	DC	18	V
	V _{EE}		-15	V
Input Voltage	V _I	Between pin13 and pin14	-1~+7	V
Output Voltage	V _O	Output voltage "H"	V _{CC}	V
Output Current	I _{g on}	Pulse width 2μs	+5	A
	I _{g off}	Frequency f=20kHz	-5	A
Isolation Voltage	V _{iso}	Sine wave voltage 50Hz / 60Hz, 1 min.	3750	V
Junction Temperature	T _J		150	°C
Operation Temperature	T _{op}		-20~+70	°C
Storage Temperature	T _{st}		-40~+125	°C
Fault Output Current	I _{FO}		20	mA
Input Voltage	V _{R1}	Pin 1 voltage	50	V

Notes: 1. Ta=25°C unless otherwise specified.
2. *20V<V_{CC}-V_{EE}<28V.

ELECTRICAL CHARACTERISTIC

Characteristics	Test Conditions	Value			Units	
		Min	Typ.	Max		
Supply Voltage	V _{CC}	14	15	-	V	
	V _{EE}	-7	-	-10	V	
Pull-up voltage on input side	V _{IN}	Recommended Range	4.75	5	5.25	V
"H" input current	I _{IH}	Recommended Range	15.2	16	19	mA
Switching frequency	f	Recommended Range			20	kHz
Gate resistant	R _G	Recommended Range	2			Ω
"H" input current	I _{IH}	V _{IN} =5V	-	16	-	mA
"H" output voltage	V _{OH}		13	14	-	V
"L" output voltage	V _{OL}		-6	-	-9	V
"L-H" propagation	t _{PLH}	I _{IH} =16mA	-	0.5	1	μs
"L-H" rise time	t _r	I _{IH} =16mA		0.6	1	μs
"H-L" propagation	t _{PHL}	I _{IH} =16mA		1	1.3	μs
"H-L" fall time	t _f	I _{IH} =16mA		0.4	1	μs
Protection threshold voltage	V _{OCP}	V _{CC} =15V, V _{EE} =-10V		8.4		V
Protection reset time	t _{timer}		1	1.3	2	ms
Fault output current	I _{FO}	Pin8 input current, R=4.7K		5		mA
Controlled time detect short circuit 1	T _{trip1}	Pin1: ≥15V, Pin2: open		2.6		μs
Controlled time detect short circuit 2	T _{trip2}	Pin1:≥15V Pin2- Pin4:1000pF		3		μs
Soft turn-off time	T _{off2}	PIN1:≥15V, PIN2: open		5		μs
SC detect voltage	V _{SC}	Collector voltage of module	15			V

Notes: 1. Ta=25°C, V_{CC}=15V, V_{EE}=-10V. unless otherwise specified
2. "H"represents high level; "L" represents low level.

APPLICATION EXAMPLES

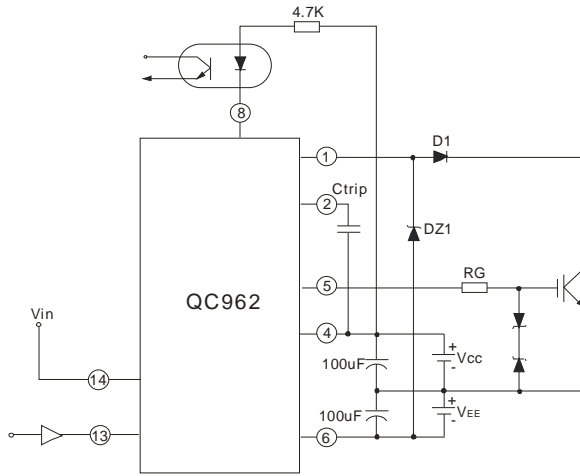

TTL compatible input interface $f=20\text{kHz}$
 Duty:50% $V_{CC}=15\text{V}$
 $V_{IN}=5\text{V}$ $V_{EE}=10\text{V}$
 $R_G=3.1\Omega$ $C_{trip}=0\sim 3300\text{pF}$
 D_1 :Fast Recovery Diode($t_{rr}\leq 0.2\mu\text{s}$)

APPLICATION NOTES

1. The IGBT gate-emitter drive loop wiring must be shorter than one meter.
2. The IGBT gate-emitter drive loop wiring should be twisted.
3. If large voltage spike is generated at the collector of the IGBT, increase the IGBT gate resistor.
4. Pin3,7,9,10 are used only for the test circuit and not be connected with the application circuit.
5. The external blocking capacitors must be connected as close as possible to the driver's pin.
6. Peak reverse voltage of the diode D1 must be higher than the peak value of the IGBT collector voltage.
7. The distance between the capacitor Ctrip and pin2-4 should be as short as possible(Max.5cm)
8. Pin1 voltage could be high due to the reverse recovery characteristic of the diode D₁ and the 30V zener diode DZ1 is connected between pin1 and pin6 for protecting the driver.

OUTLINE DRAWING

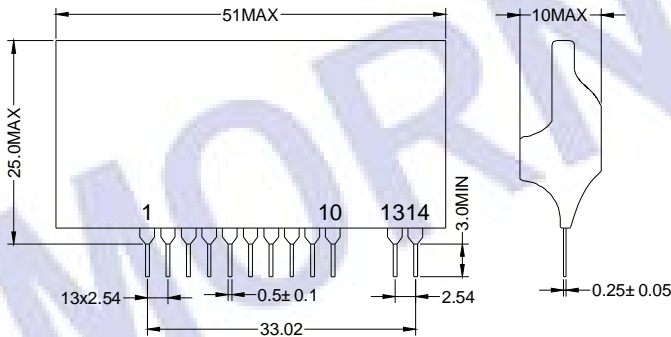

PIN FUNCTION:

Pin number	Description
1	Fault detect
2	Reaction time
4	Power supply(+)
5	Drive output
6	Power supply(-)
8	Fault signal output
13	Drive signal input(-)
14	Drive signal input(+)
3, 7, 9, 10	Not connected