

MORNSUN

QP12W05S-37

Hybrid Integrated IGBT Driver

QP12W05S-37 is a hybrid integrated IGBT driver designed for driving IGBT modules. This device is a fully isolated gate drive circuit consisting of an optimally isolated gate drive amplifier and an isolated DC-to-DC converter. The gate driver provides an over-current protection function based on desaturation detection and fault output.

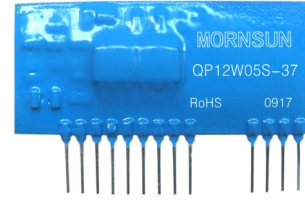

RoHS

Features

- I Built in high CMRR opto-coupler (CMR: Typical: 30kV/μs, Min.:15kV/μs)
- I Single supply drive topology
- I Built in the isolated type DC/DC converter for gate drive
- I SIP package
- I CMOS&TTL compatible
- I Electrical isolation voltage between input and output is 3750VRMS (for 1 minute)
- I Built in short circuit protection circuit with a pin for fault output
- I Soft turn-off time is adjustable
- I The drive signal is ignored in the blocking time and the protection circuit reset at the end of it
- I Controlled time detect short circuit is adjustable
- I Switching frequency up to 20kHz

Application

- I General-purpose Inverter
- I AC Servo Systems
- I Uninterruptable Power Supplies(UPS)
- I Welding Machines

Recommended modules

- I 600V Series IGBT(up to 600A)
- I 1200V Series IGBT(up to 400A)
- I 1700V Series IGBT(up to 200A)

MORNSUN Science & Technology co.,Ltd.

Address: 2th floor 6th building, Huangzhou Industrial District, Guangzhou, China
 Tel: 86-20-38601850
 Fax:86-20-38601272
[Http://www.mornsun-power.com](http://www.mornsun-power.com)

Absolute Maximum Ratings				
Item		Test Conditions	Ratings	Units
Supply Voltage	V_D	DC	16	V
Input Voltage	V_I	Between pin3 and pin4	-1 ~ +7	V
Output Voltage	V_O	When the Output voltage "H"	V_{CC}	V
Output Current	$I_{g\ on}$	Pulse width 2μs Frequency f=20kHz	+5	A
	$I_{g\ off}$		-5	A
Isolation Voltage	V_{iso}	Sine wave voltage 50Hz/60 Hz, 1 min.	3750	V
Operation Temperature	T_{op}		-40 ~ +70	°C
Storage Temperature	T_{st}		-50 ~ +125	°C
Fault Output Current	I_F		20	mA
Input Voltage	V_R	Applied pin13	50	V

Notes: 1. $T_a=25^{\circ}C$; $V_D=15V$, unless otherwise specified.

Electrical Characteristic						
Characteristics		Test Conditions	Limit			Units
			Min	Typ.	Max	
Supply Voltage	V_D	Recommended Range	14.5	15	15.5	V
Pull-up voltage on input side	V_{IN}	Recommended Range	4.75	5	5.25	V
"H" input current	I_{IH}	Recommended Range	—	16	—	mA
Switching frequency	f	Recommended Range			20	kHz
Gate resistant	R_g	Recommended Range	2			Ω
Gate supply voltage	V_C	—	14.5	—	18.0	V
	V_E	—	-7	—	-10	V
"H" output voltage	V_{OH}	15KΩconnected between pin9-11	13.5	15.3	17.0	V
"L" output voltage	V_{OL}	15KΩconnected between pin9-11	-6	—	-10	V
"L-H" propagation delay time	t_{PLH}	$I_{IH}=10mA$	—	0.5	1	μs
"L-H" rise time	t_r	$I_{IH}=10mA$		0.3	1	μs
"H-L" propagation delay time	t_{PHL}	$I_{IH}=10mA$		1	1.3	μs
"H-L" fall time	t_f	$I_{IH}=10mA$		0.3	1	μs
Protection threshold voltage	V_{OCP}	$V_D=15V$		9.5		V
Protection reset time	t_{timer}	Between start and cancel	1	1.4	2	ms
Fault output current	I_{FO}	Pin15 input current, R=4.7K		5		mA
Short-circuit detection time delay	T_{trip1}	Pin 13: ≥15V, Pin 16:open		1.6		μs
Soft turn-off time	T_{cf}	PIN 13≥15V, Pin 16:open		4.5		μs
SC detect voltage	V_{SC}	Collector voltage of module	15			V

Notes: 1. $T_a=25^{\circ}C$, $V_D=15V$, $R_g=5\Omega$. unless otherwise specified
 2. "H" represents high level; "L" represents low level.

Definition of Characteristics

1) Operation of short circuit protection

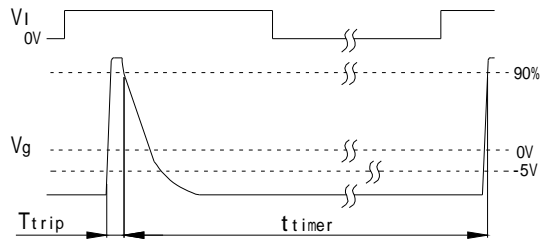

2) Switching operation

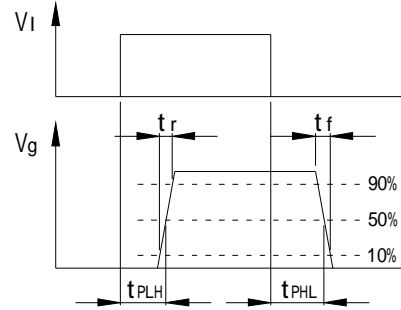

Definition of Adjustment

1) Adjustment of soft turn-off time:

(Operation of short circuit protection)

When a desaturation is detected the hybrid gate driver performs a soft shutdown of the IGBT. The Soft turn-off time is 4.5uS. You can connect an Rf or Cf to adjust the Soft turn-off time. (Connecting Rf will increase the soft turn-off time and connecting Cf will decrease the soft turn-off time.) The soft turn-off time must be set $2.5\mu\text{s} < T_{cf} < 10\mu\text{s}$. Please refer to the below table.

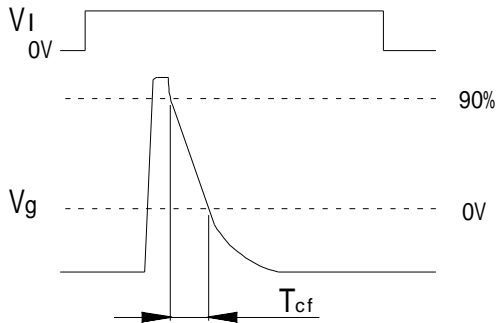

The soft turn-off time & Rf, Cf			
Rf (Ω)	Tcf (μS)	Cf (nF)	Tcf(μS)
—	4.5	—	4.5
1500	4.0	1	4.9
500	3.5	3.3	5.3
300	3.0	10	6.5
110	2.5	22	9.3

2) Adjustment of short-circuit detection time delay

(Operation of short circuit protection)

The short-circuit detection time delay is defined between the time in which a desaturation is detected and the time in which the gate voltage fall down to 90% of extent. This diver have a minimum short-circuit detection time delay, and you can adjust the short-circuit detection time delay by connecting the capacitor (Ctrip) between PIN12 and 16. But the short-circuit detection time delay must be set less than 3.5uS. Please refer to below table.(the data only for refer)

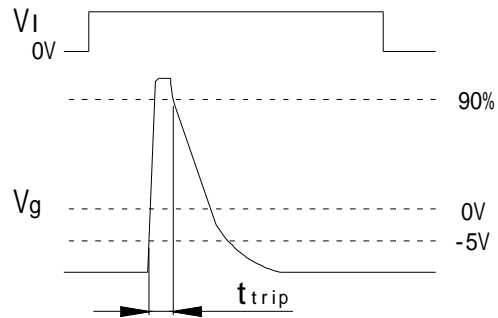

The short-circuit detection time delay & capacitor Ctrip	
Ctrip (nF)	Ttrip(μS)
—	1.6
0.33	1.8
1.0	2.2
2.2	2.4
3.3	2.6

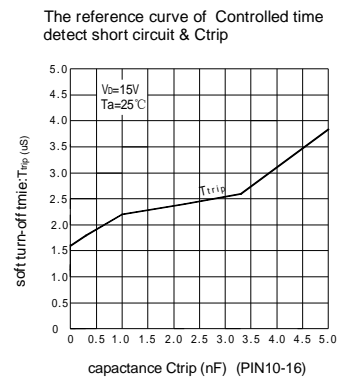
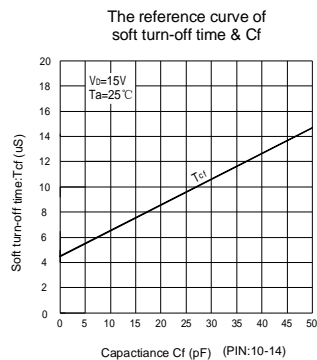
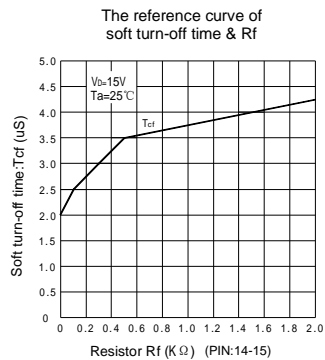

Outline Dimensions (Unit:mm)

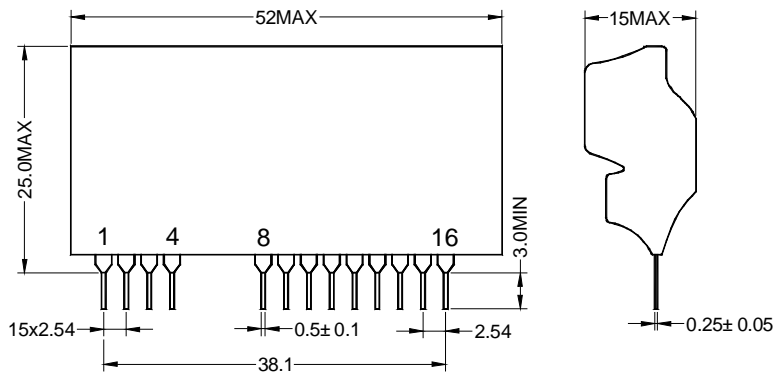

Note:
Unit: mm
General tolerances: ± 0.3 mm

PIN FUNCTION:

Pin	Description
1	Power supply(+)
2	Power supply(-)
3	Drive signal input(+)
4	Drive signal input(-)
8	DC/DC converter output(+)
9	DC/DC converter output(COM)
10	DC/DC converter output(-)
11	Drive output
12	Collector
13	Detect of short circuit
14	Adjustment of Soft turn-off time
15	Fault signal output
16	Adjustment of short-circuit detection time delay

Application Examples

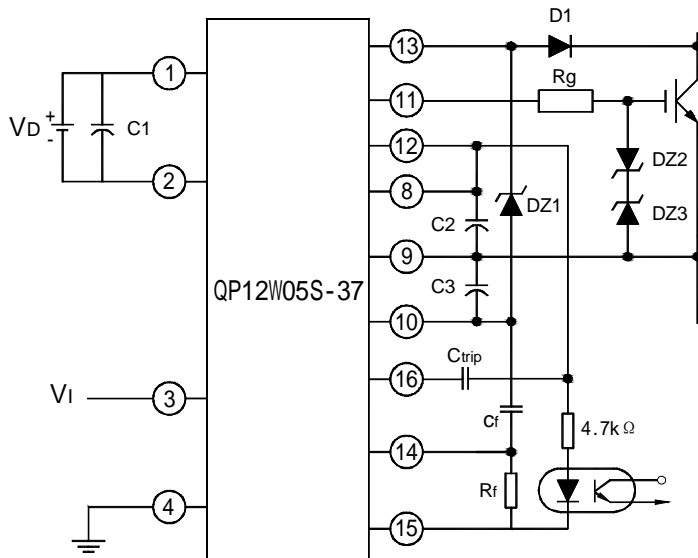

$V_D=15V$
 $V_I=5V\pm 5\%$
C1:100uF (Low impedance)
C2:100uF (Low impedance)
C3:100uF (Low impedance)
Ctrip: Depend on need.
Cf: Depend on need
Rf: Depend on need
Rg:5Ω (Adjustable)
DZ1:30V
DZ2, DZ3:18V
D1: Fast recovery diode ($t_{rr}\leq 0.2\mu s$)

Application Notes

1. The isolated DC/DC converter is only for the gate drive;
2. The IGBT gate-emitter drive loop wiring must be shorter than 1 meter;
3. The IGBT gate-emitter drive loop wiring should be twisted;
4. If large voltage spike is generated at the collector of the IGBT, the IGBT gate resistor should be increased;
5. The external capacitors or resistors should be set as close as possible to the Hybrid IC;
6. The voltage compensate capacitors should be low impedance and be located as close as possible to the Hybrid IC;
7. The peak reverse voltage of the diode D1(to connect PIN13) must be higher than the peak value of the IGBT collector voltage;
8. When recovery current flow in D1, PIN13 is applied high voltage. In the case, counterplan for protection which insert a zener diode between PIN10 and 13 are necessary like above diagram(DZ1);
9. When the built in short-circuit protection circuit need not be used, please connect resistance of 4.7kΩ between PIN9 and 13(D1and DZ1are not required).